



Distributed by:



OST 250

ERGONOMIC & COMFORTABLE MOTORIZED
REFRACTION UNIT FOR DAILY USE

NO AKL: KEMENKES RI AKL 10102911272



OST 250 WITH AGILITY PACK*

OST 250 CONFIGURATION:

Motorized chair (elevation path 18 cm)
 Sliding table top 90°
 Lift-up elbow rests
 Footrests
 Fixed chinrest
 Right or left handed version
 Keypad
 Dual voltage (110V / 220V)

*AGILITY PACK includes:

- « Optima » design
- Motorized elevation table
- Tilting backrest 90°
- Storage drawer (60 x 350 x 70 mm)

OPTIONS:

Near vision lamp
 LCD screen support
 Chart projector holder
 Stand for keyboard
 Side unit body covers:

- Red (RAL 3001)
- Blue (RAL 5005)
- White (RAL 9016)

Motorized elevation table



Tilting backrest 90°



Drawer



OST 250 WHEEL CHAIR ACCESS OPTION



Wheel chair access (available with OST 250H configuration)

The movable patient chair combined to compact design, motorized elevation and tilting backrest allow adjustment of the unit to the individual needs of patients bound to a wheel chair. A unit to optimize your practice with limited footprint and maximum agility.

SPECIFICATIONS

Chair maximum load:

150 kg

Sliding tabletop:

Dimensions: 42 x 82 cm

Max. weight: 40 kg

Versions:

Right or left handed version

Power supply:

110/230 V- 50/60 Hz

Dimensions:

1.26 (L) x 2.14 (P) x 1.90 (H) m

Weight:

240 kg

OST 250. Side view

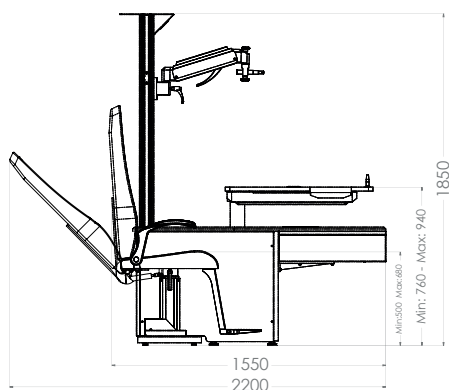

OST 250. Top view

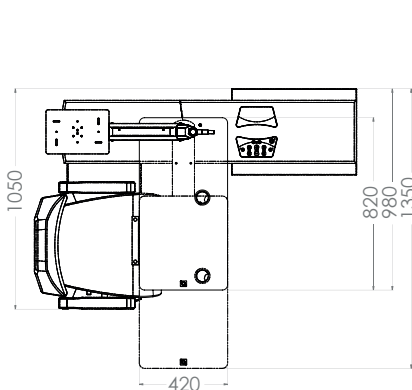

OST 250 H. Side view full tilt

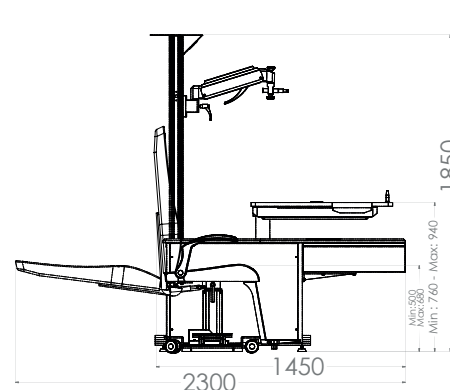

ESSILOR INSTRUMENTS

81 boulevard Jean-Baptiste Oudry
 94000 Créteil
 France
 Tél. 33(0)1 49 80 62 80
www.essilor-instruments.com

Distributed by:



PT. Meta Mata Medika www.metamedika.com
 MASPION PLAZA, Jl. Gunung Sahari Raya Kav.18, 3rd Floor Unit 3F
 Jakarta Utara, INDONESIA 14420
 Tel. + 62 21 6470 1108, Fax. +62 21 6470 1114 • Email. info@metamedika.com